

REVISIONS				
ZONE	REV	DESCRIPTION	DATE	APPROVED

# Booster Bottom Centering Ring

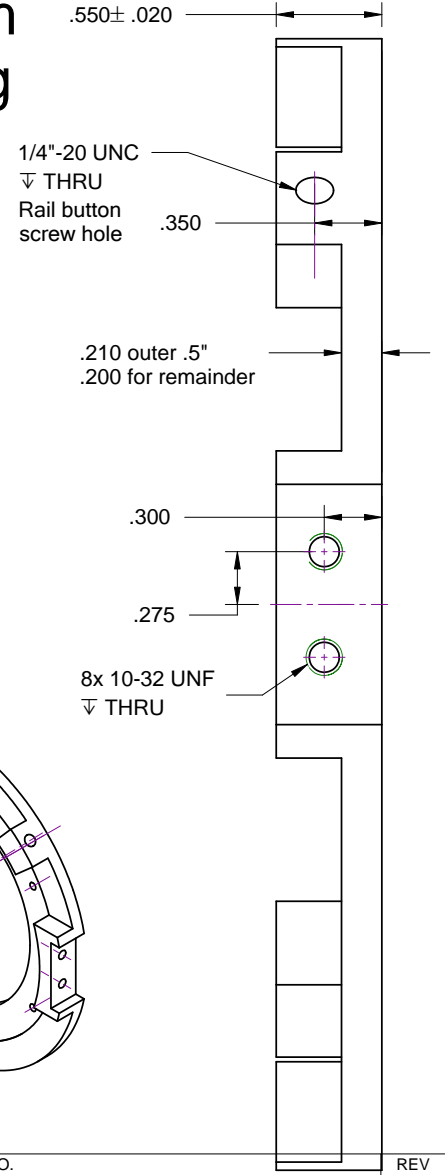
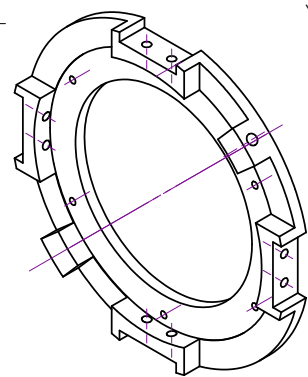
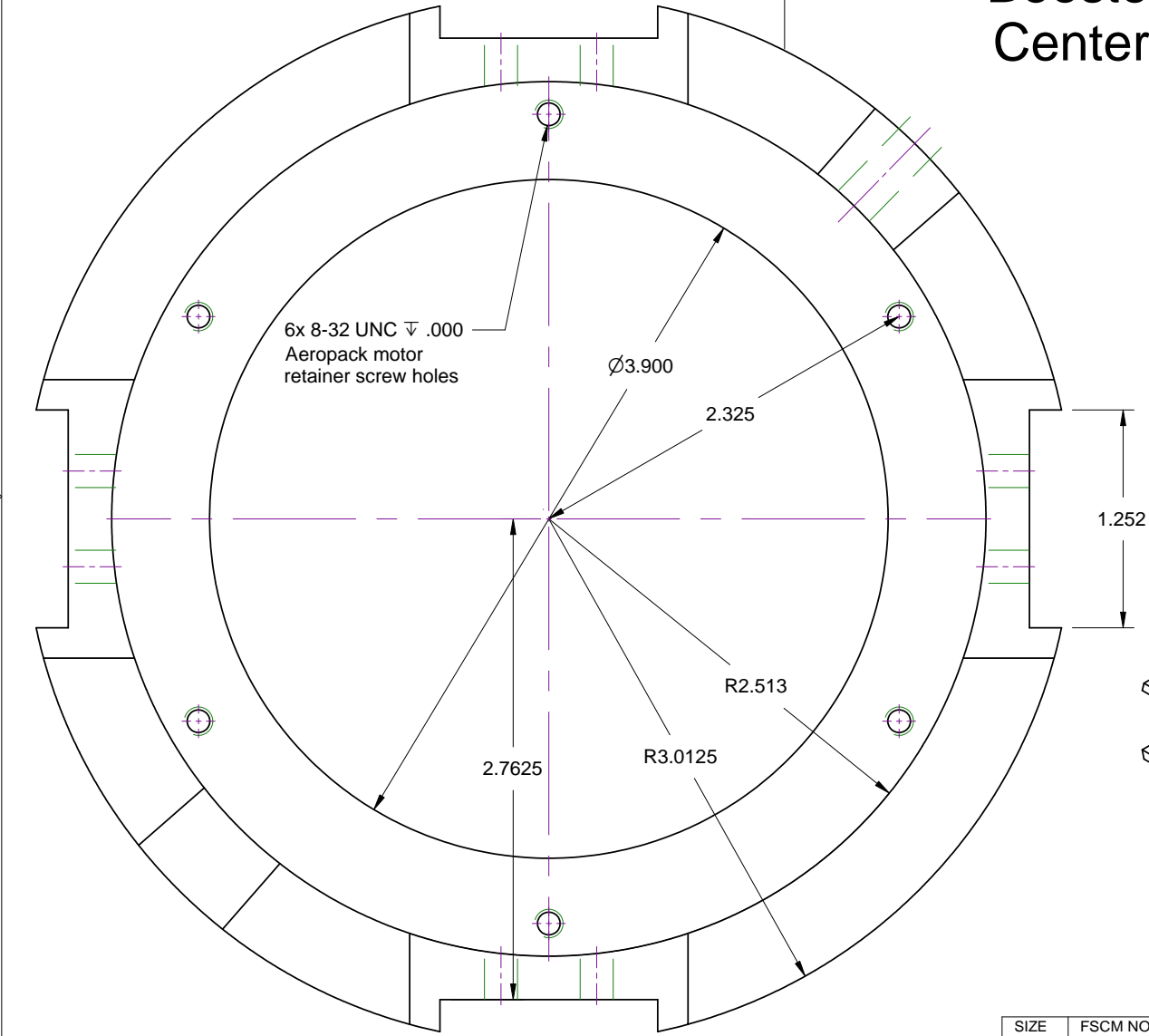

SIZE <b>A</b>	FSCM NO.	DWG NO.	REV
SCALE	B. Feretich & G. Saviers		SHEET

REVISIONS				
ZONE	REV	DESCRIPTION	DATE	APPROVED

# Booster Bottom Centering Ring

(Milled Pockets)

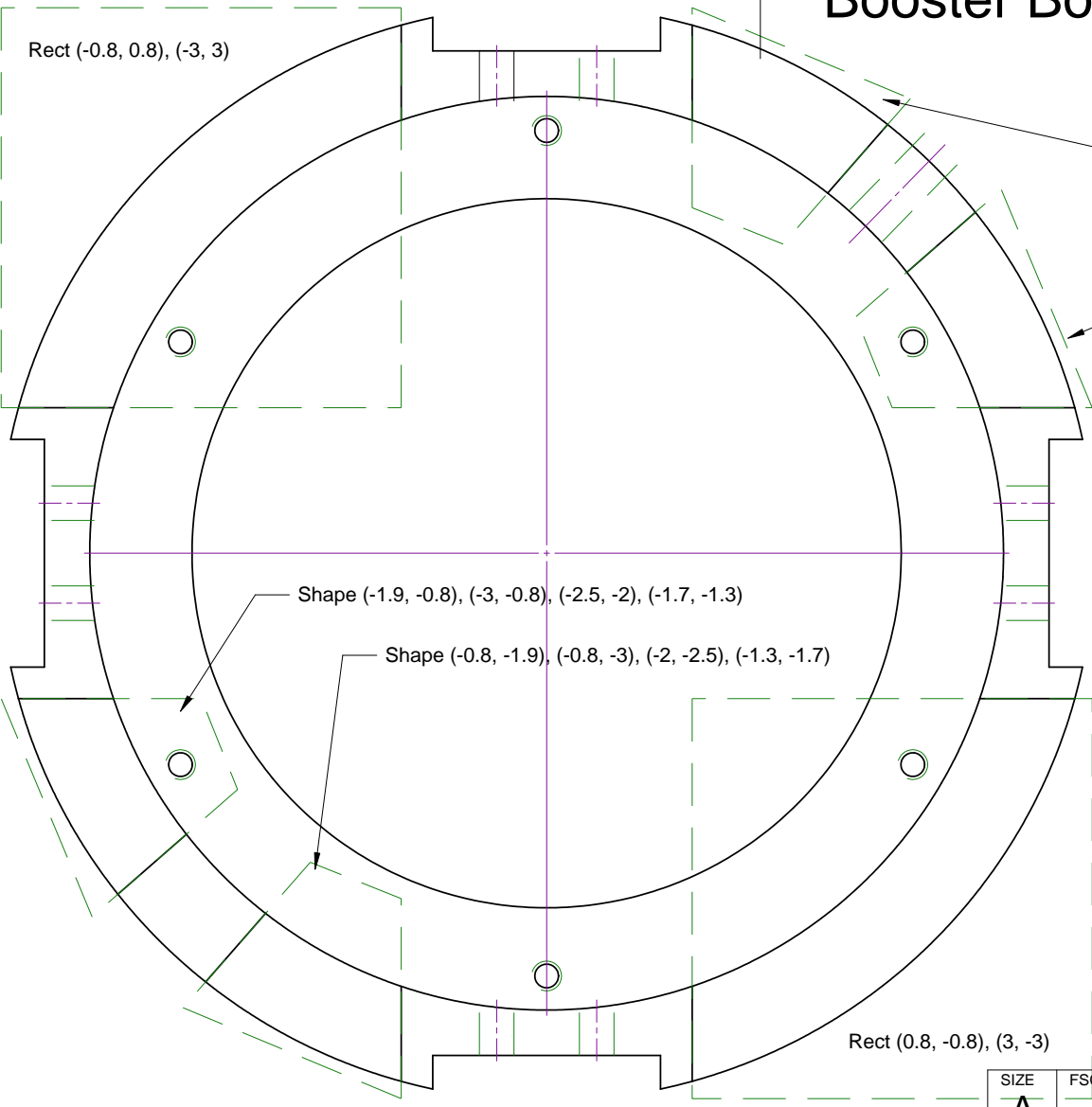

All milled pockets are machined to +0.01 above height of inner ring surface.

SIZE <b>A</b>	FSCM NO.	DWG NO. B. Feretich & G. Saviers	REV
SCALE	SHEET		