

Aluminum bulkheads are grounded to BeeLine GPS antenna shield.  
 All binder posts on bulkheads are bypassed to this ground via .001uf ceramic capacitors to prevent RF noise from the BeeLine antenna from entering the avionics compartment.

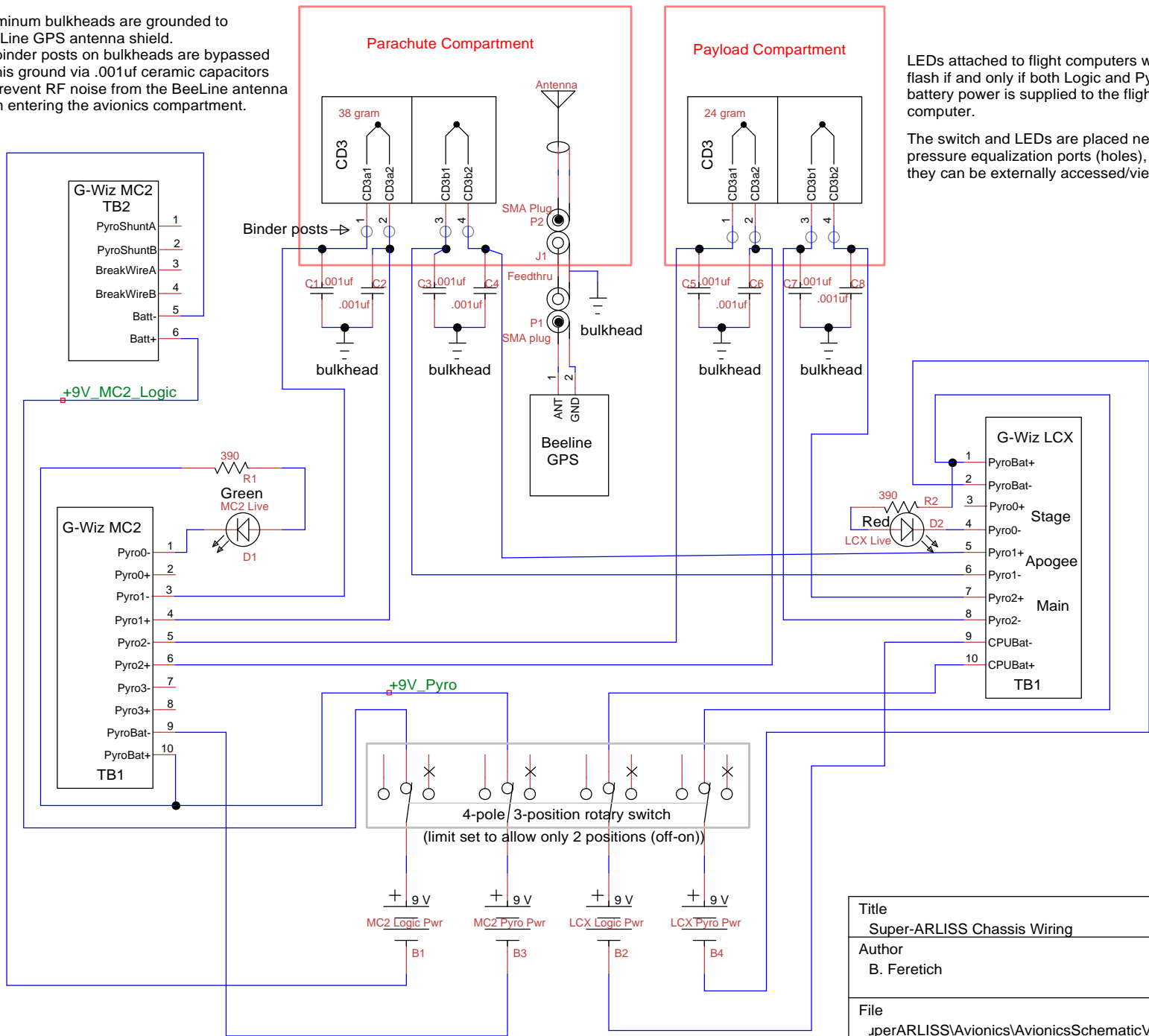

LEDs attached to flight computers will flash if and only if both Logic and Pyro battery power is supplied to the flight computer.  
 The switch and LEDs are placed near pressure equalization ports (holes), so they can be externally accessed/viewed.

Title Super-ARLISS Chassis Wiring		
Author B. Feretich		
File _perARLISS\Avionics\AvionicsSchematicV3.dsn	Document	
Revision 3.0	Date 8/30/07	Sheets 1 of 1