

REVISIONS				
ZONE	REV	DESCRIPTION	DATE	APPROVED

Attitude Stability System Mid #1 Plate

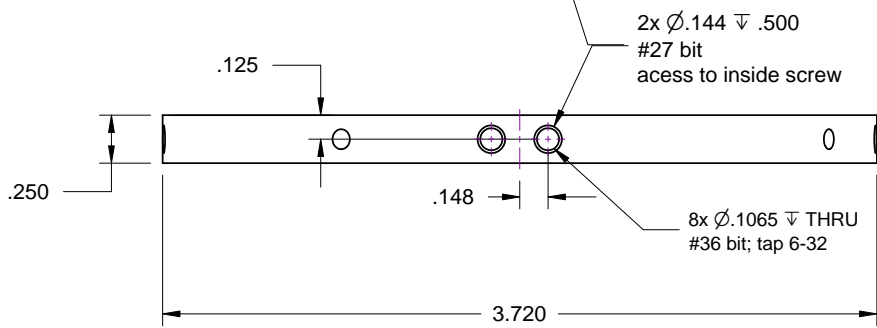
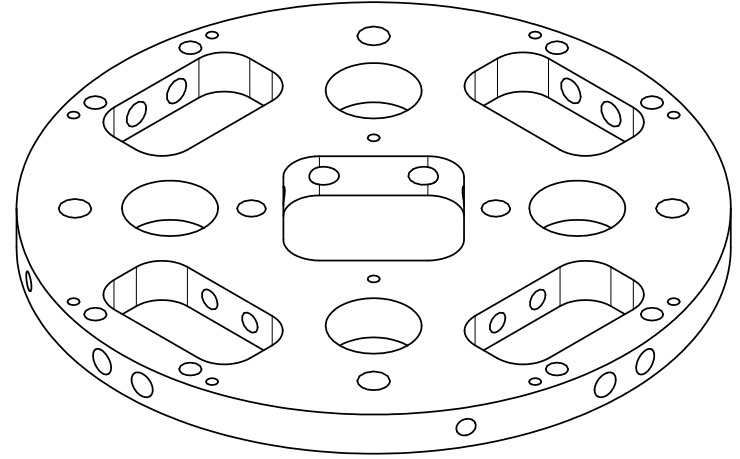
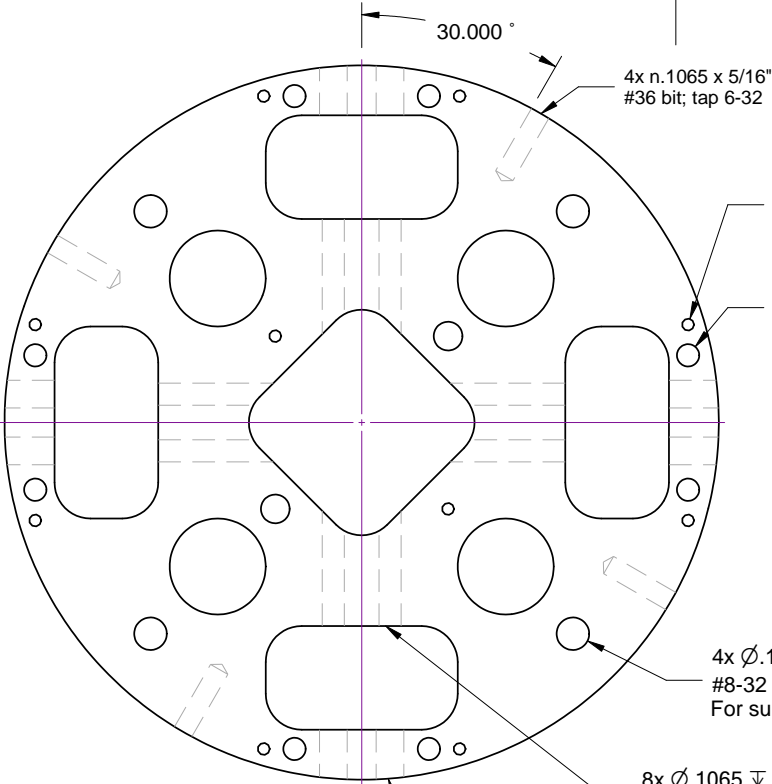

SIZE A	FSCM NO.	DWG NO.	REV
SCALE	B. Feretich		SHEET

REVISIONS				
ZONE	REV	DESCRIPTION	DATE	APPROVED

Attitude Stability System Mid #1 Plate Milling Guide

All cuts use $\sim 3/8$ " end mill.

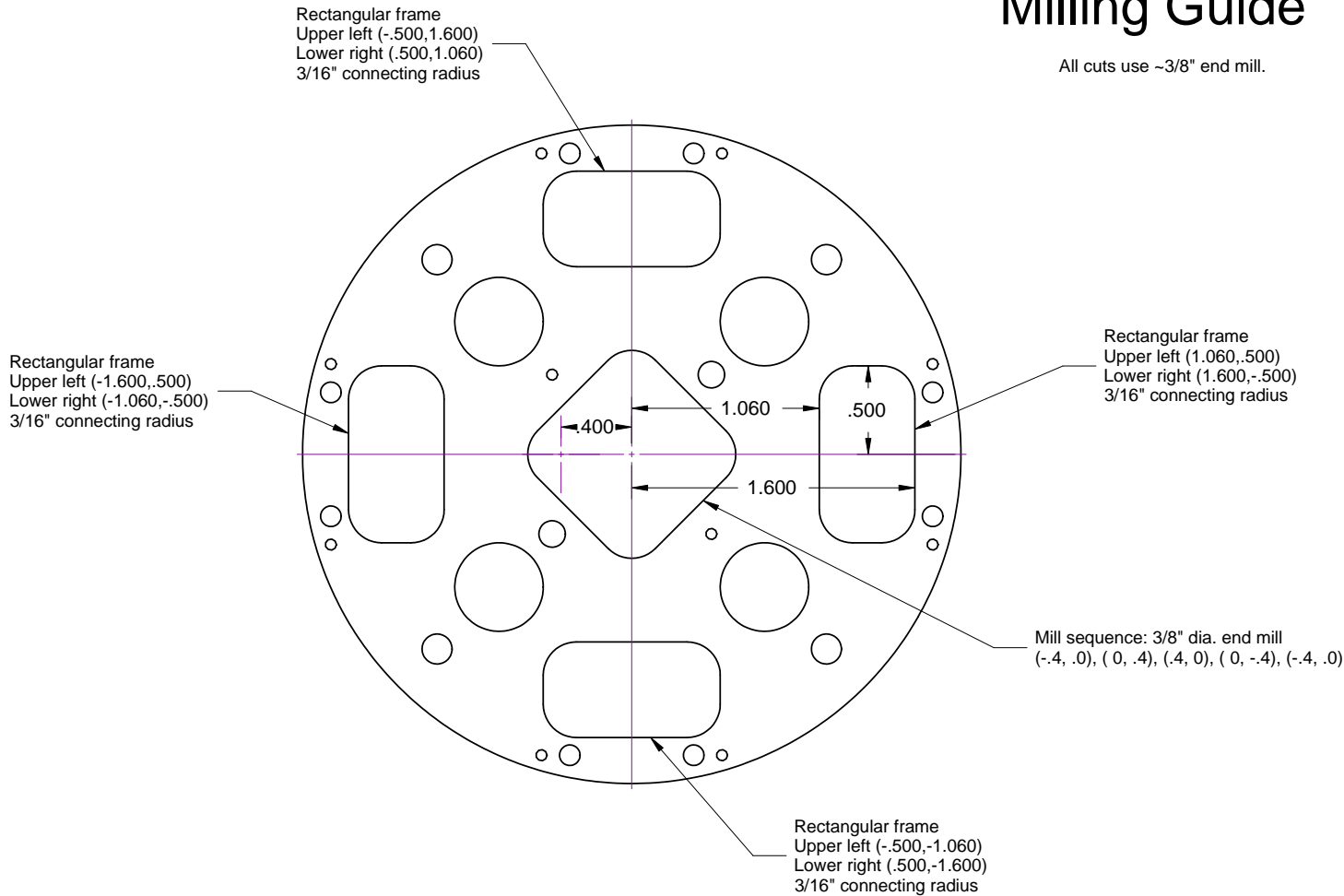

SIZE A	FSCM NO.	DWG NO.	REV
SCALE	B. Feretich		SHEET



REVISIONS

ZONE	REV	DESCRIPTION	DATE	APPROVED
------	-----	-------------	------	----------

Attitude Stability System Mid #1 Plate Drilling Guide

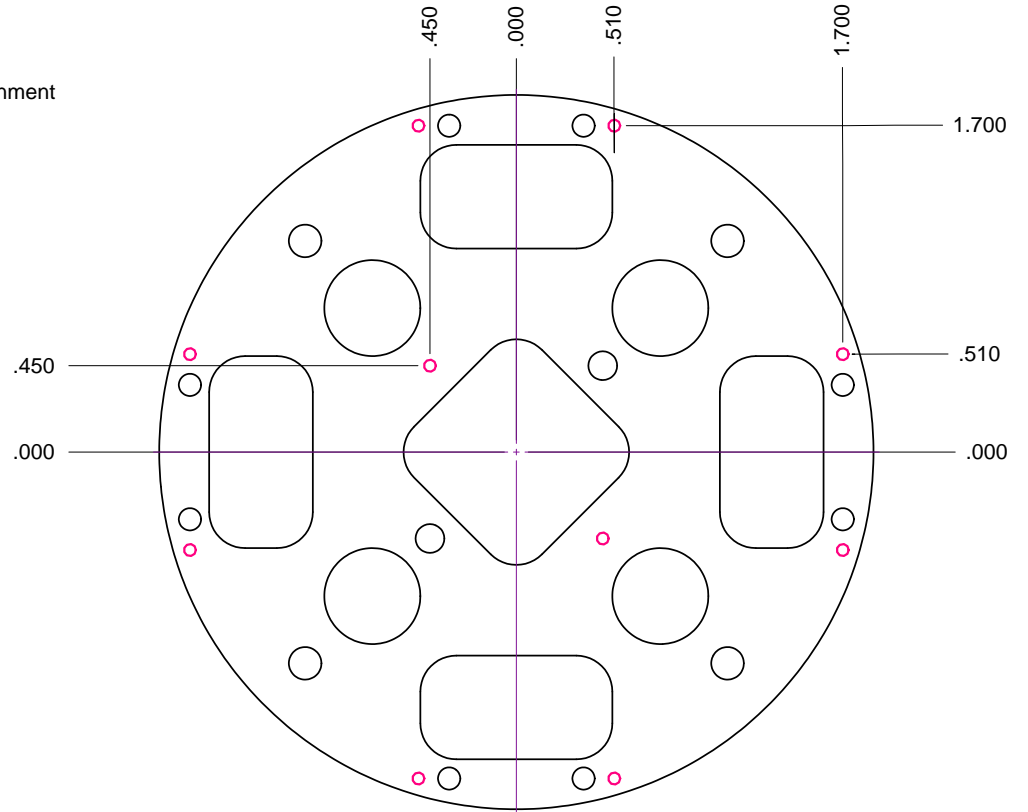
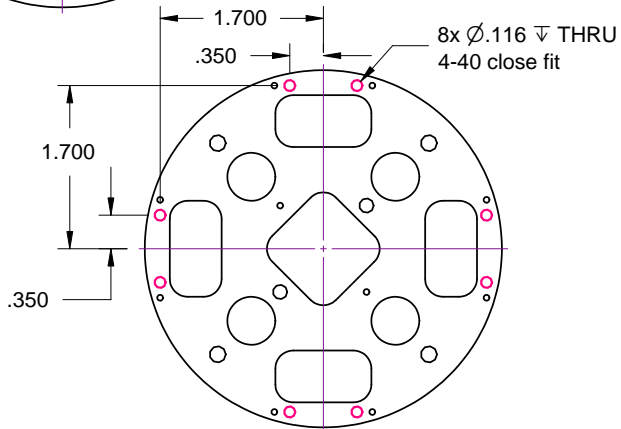
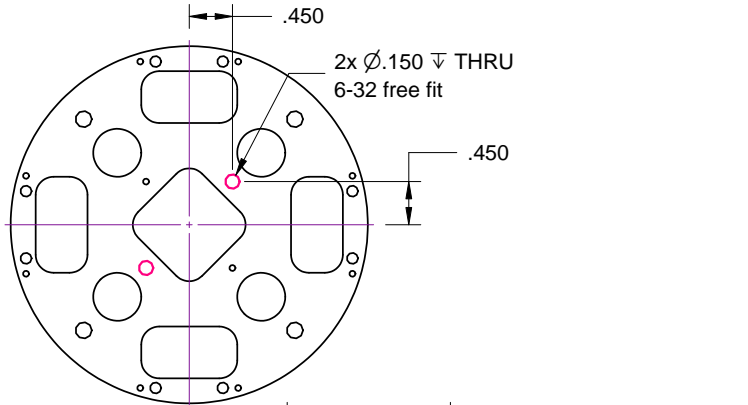
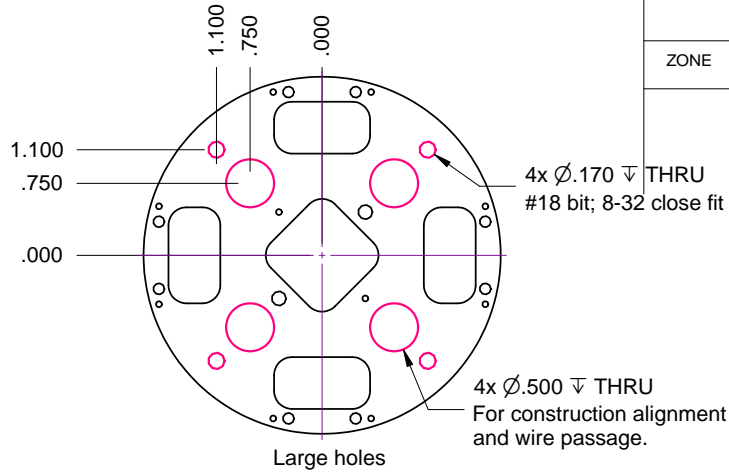

Slip fit alignment pin holes
10 holes
Drilled .0591"; #53 bit
Reamed .0625" +.003/-.000; #52 reamer

SIZE A	FSCM NO.	DWG NO.	REV
SCALE	B. Feretich		SHEET

